

FD/G Series 20-25

Counter Balanced Forklift



Wide view mast VM

Mast model	Load center 500mm		Max lift height	Mast height		Tilt range fwd / bwd	(3) Weight	
	FG/D 20	FG/D 25		fork lowered	(1) fork lift with backrest		FG/D 20	FG/D 25
	kg	kg		mm	mm		mm	kg
VM250	2000	2500	2500	1745	3530	6-12	3200	3540
VM270	2000	2500	2700	1845	3730	6-12	3215	3555
VM300	2000	2500	3000	1995	4030	6-12	3240	3580
VM330	2000	2500	3300	2145	4330	6-12	3265	3605
VM350	2000	2500	3500	2245	4530	6-12	3280	3620
VM375	2000	2500	3750	2370	4780	6-6 +6-12	3295	3635
VM400	2000	2500	4000	2545	5030	6-6 +6-12	3340	3680
VM425	1950 +2000	2450 +2500	4250	2670	5280	6-6 +6-12	3360	3700
VM450	1900 +1950	2150 +2450	4500	2795	5530	6-6 +6-12	3380	3720
VM475	1800 +1850	1850 +2350	4750	2920	5780	6-6 +6-6	3400	3740
VM500	1650 +1700	1700 +2250	5000	3045	6030	6-6 +6-6	3420	3760
VM550	+1500	+1700	5500	3345	6530	+3-6	3615	3955
VM600	+1300	+1400	6000	3595	7030	+3-6	3655	3995

2 stage free lift mast VFM

Mast model	Load center 500mm		Max lift height	Mast height		(2) free lift with backrest	Tilt range fwd / bwd	(3) Weight	
	FG/D 20	FG/D 25		fork lowered	(1) fork lift with backrest			FG/D 20	FG/D 25
	kg	kg		mm	mm			mm	kg
VFM250	2000	2500	2500	1745	3530	745	6-12	3260	3600
VFM270	2000	2500	2700	1845	3730	845	6-12	3275	3615
VFM300	2000	2500	3000	1995	4030	995	6-12	3305	3645
VFM330	2000	2500	3300	2145	4330	1145	6-12	3330	3670
VFM350	2000	2500	3500	2245	4530	1245	6-12	3345	3685

3 stage free lift mast VFHM

Mast model	Load center 500mm		Max lift height	Mast height		(2) free lift with backrest	Tilt range fwd / bwd	(3) Weight	
	FG/D 20	FG/D 25		fork lowered	(1) fork lift with backrest			FG/D 20	FG/D 25
	kg	kg		mm	mm			mm	kg
VFHM360	2000	2500	3600	1745	4630	745	6-6 +6-10	3410	3750
VFHM400	2000	2500	4000	1870	5030	870	6-6 +6-10	3445	3785
VFHM435	1900 +2000	2200 +2400	4350	1995	5380	995	6-6 +6-10	3475	3815
VFHM480	1700 +1900	1900 +2300	4800	2145	5830	1145	6-6 +6-10	3515	3855
VFHM500	1500 +1800	1600 +2250	5000	2245	6030	1245	6-6 +6-10	3535	3875
VFHM540	1200 +1750	1300 +2150	5400	2370	6430	1370	3-6 +3-6	3565	3905
VFHM600	900 +1650	950 +1800	6000	2595	7030	1595	3-6 +3-6	3655	3995
VFHM650	+1500	+1550	6500	2810	7530	1810	+3-3	3835	4175
VFHM700	+1250	+1250	7000	3030	8030	2030	+3-3	3885	4225

Notes: (1) Max. Lift height (without backrest): 470mm; (2) Free lift height without backrest: +470mm; Weight without backrest: 20kg; (3) Diesel forklift weight: +90kg
 Notes: The mark of * is with double tires, the weight with double tires: +120kg
 Lift speed with VFM/VFHM: VFM: FG 400mm/s full load, 450mm/s no load; FD 400mm/s full load, 420mm/s no load
 VFHM: FG 410mm/s full load, 470mm/s no load; FD 420mm/s full load, 440mm/s no load.
 Lowering speed: VFM/VFHM 400mm/s full load, 300mm/s no load.



Anhui TEU Forklift Truck Co., Ltd.

Sales department

Tel: +86-551-62654001 62654008

Fax: +86-551-62654808

Zip: 230001

Add: No. 124, Lujiang rd, Hefei, Anhui, China

E-mail: admin@anhuiteu.com.cn

Distributor:

Three Features



1 Cleaner, more efficient Engines

New engines, compliant with worldwide stage IIIA emission regulations (ISUZU C240PKJ Diesel powered engine)

2 Easy Maintenance

Detachable side covers for convenient inspection and simple maintenance. Integral layout of electrical parts and other system devices.

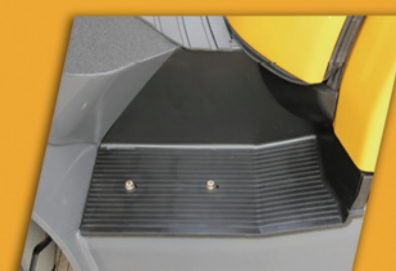

3 Easier entry and exit form an extra-wide step

The secure step with enlarged foot space enables greater comfort and less fatigue while entering and exiting the vehicle.



Main Truck Specifications

Specifications		TEU							
		Power shift T/M		FG20T	FG25T	FD20T	FD25T	FD20T	FD25T
2 Model		Manual shift T/M		FG20C	FG25C	FD20C	FD25C	FD20C	FD25C
3 Load capacity		kg		2000	2500	2000	2500	2000	2500
4 Load center		mm		500	500	500	500	500	500
5 Power unit		Gasoline / LPG				Diesel			
6 Operator type		Driver / seat				Driver / seat			
7 Tire type	Front/rear	Pneumatic				Pneumatic			
8 Wheels	Front/rear	2/2				2/2			
9 Max. lifting height		mm		3000	3000	3000	3000	3000	3000
10 Free lift		mm		160	160	160	160	160	160
11 Fork size	L × W × T	mm		1070 × 122 × 40	1070 × 122 × 40	1070 × 122 × 40	1070 × 122 × 40	1070 × 122 × 40	1070 × 122 × 40
12 Tilt range	Mast forward / Back ward	deg		6/12	6/12	6/12	6/12	6/12	6/12
13 Overall length (without fork)		mm		2460	2530	2460	2530	2460	2530
14 Total width		mm		1150	1150	1150	1150	1150	1150
15 Mast height (fork lowering)		mm		1995	1995	1995	1995	1995	1995
16 Overall height fork raised (with backrest)		mm		4030	4030	4030	4030	4030	4030
17 Height of head guard		mm		2120	2120	2120	2120	2120	2120
18 Turning radius (outside)		mm		2170	2240	2170	2240	2170	2240
19 Load distance		mm		450	450	450	450	450	450
20 Right angle stacking aisle (not add load length & clearance)		mm		2615	2690	2615	2690	2615	2690
21 Speed	Max. travelling	full	km/h	17	17	17	17	17	17
		no load	km/h	19	19	19	19	19	19
	Lifting	full	mm/s	550	550	550	550	550	550
		no load	mm/s	580	580	580	580	580	580
Lowering	full	mm/s	450	450	450	450	450	450	
	no load	mm/s	550	550	550	550	550	550	
24 Max. drawbar pull	Power shift T/M	full/no load	kg	1650/830	1670/830	1670/830	1670/830	1670/830	1670/830
	Manual shift T/M	full/no load	kg	1700/830	1700/830	1700/830	1700/830	1700/830	1700/830
25 Gradeability at 1.6km/h	Power shift T/M	full/no load	%	25/20	22/18	27/20	23/18	27/20	23/18
	Manual shift T/M	full/no load	%	25/20	22/18	21/20	18/18	21/20	18/18
26 Truck weight	Full load	front	kg	4660	5370	4700	5410	4700	5410
		rear	kg	580	710	630	760	630	760
	No load	front	kg	1470	1390	1510	1430	1510	1430
		rear	kg	1770	2190	1820	2240	1820	2240
27 Tires	Number	front / rear		2/2	2/2	2/2	2/2	2/2	2/2
		Model	front	7.00-12-12PR	7.00-12-12PR	7.00-12-12PR	7.00-12-12PR	7.00-12-12PR	7.00-12-12PR
	Wheelbase	front	mm	1600	1600	1600	1600	1600	1600
		rear	mm	970	970	970	970	970	970
33 Tread	Front	mm	970	970	970	970	970	970	
	Rear	mm	970	970	970	970	970	970	
34 Ground clearance	At lowest point (mast)	mm	110	110	110	110	110	110	
	Frame	mm	115	115	115	115	115	115	
35 Brake	Service brake			Hydraulic - foot pedal	Hydraulic - foot pedal	Hydraulic - foot pedal	Hydraulic - foot pedal	Hydraulic - foot pedal	Hydraulic - foot pedal
	Parking brake			Mechanical - hand lever	Mechanical - hand lever	Mechanical - hand lever	Mechanical - hand lever	Mechanical - hand lever	Mechanical - hand lever
36 Battery	Voltage / capacity	V/AH		12/60	12/80	12/80	12/80	12/80	12/80
	Model			K21	C240	490BPG	490BPG	490BPG	490BPG
	Rated power	KW/rpm		31.2/2250	34.3/2500	37/2650	37/2650	37/2650	37/2650
	Rated torque	N m/rpm		144/1600	138/1800	148/1800	148/1800	148/1800	148/1800
	Number of cylinder			4	4	4	4	4	4
37 Engine	Displacement	L		2.065	2.369	2.540	2.540	2.540	2.540
	Fuel tank capacity	L		70	70	70	70	70	70
38 Transmission	Speed forward / backward			1-1Power shift T/M	1-1Power shift T/M	1-1Power shift T/M	1-1Power shift T/M	1-1Power shift T/M	1-1Power shift T/M
	Power shift T/M			2-2Manual shift T/M	2-2Manual shift T/M	2-2Manual shift T/M	2-2Manual shift T/M	2-2Manual shift T/M	2-2Manual shift T/M
39 Operating pressure	Hydraulic system pressure	kg/cm ²		180	180	180	180	180	180
	Manual shift T/M			180	180	180	180	180	180

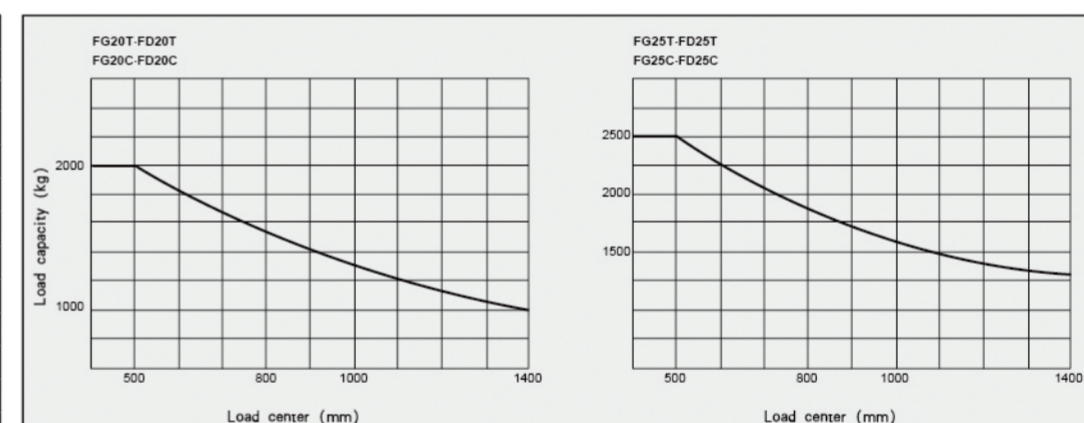

Notes:

Vertical axis represents load capacity; Horizontal axis shows load center. Load center are determined from front face of the fork. Capacity based on a 1000mm cube load configuration with the center of gravity at the true center of the cube, and standard fork. The load capacity will be reduced while the mast tilt forward or loading with long fork or lifting transformable width of goods. Getting the load capacities at the various load centers timely via the load curve. TEU's products and specifications change without prior notice. TEU forklift truck has equipped with standard safety device. TEU is not responsible for the damage occurred by removing its safety device.

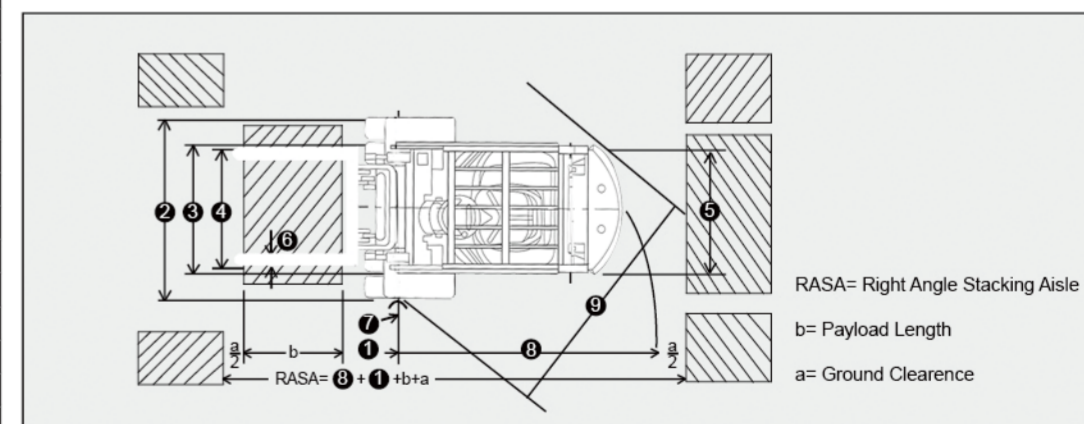

Specifications (front single tires)

Model	FG/D20C - FG/D20T (mm)	FG/D25C - FG/D25T (mm)
1 Front Overhang	450	450
2 Total Width	1150	1150
3 Front Track	970	970
4 Fork Spread (outside)	245-1020	245-1020
5 Rear Track	970	970
6 Fork Width	122	122
7 Turning Radius (inside)	160	160
8 Turning Radius (outside)	2170	2240
9 Right Angle Turning Aisle	1920	2010

Standard equipments:

Wide view mast, Cyclone air cleaner, Load one-way valve, Preheat indicator, King Pin, Engine-start switch, Standard backrest, Long-life tires, Overhead guard, Oil and water separator, Power steering, Adjustable steering column, Radiator water tank, Side roller, Standard carriage, Oil temperature cooler, Headlamp and steering indicator lamp, Charge indicator lamp, Hour meter, Oil warning light of engine, Water temperature gauge, Fuel gauge, Reversing light, Electric horn, Neutral-safety switch, Rear mirror, Tools, Reversing Buzzer, General seat.

Options:

Fire extinguisher, cab, Heater unit, Rear work light, Solid tires, Fireproof silencer, Upper exhaust pipe, Tilt cylinder jacket, Rotating warning light, LPG Conversion device, Pre-filtration air intake device.

Attachments:

Side shifter, Fork positioned, Carpet boom, Fork extension, Long fork Flat clamp, Others